

Crane & Overhead Lifting **Pallet Hooks**

Type PHA 2000 Pallet Hook

The PHA 2000 automatic pallet hook is self levelling for easy operation. The unit self balances using an internal spring mechanism ensuring the lifting eye is in the correct position to keep the fork tines horizontal. Tine width is also adjustable on the PHA 2000. Enamel paint finish.

- Safe Working Load: 2000 kg
- Load Centre: 600 mm
- Unit Weight: 196 kg

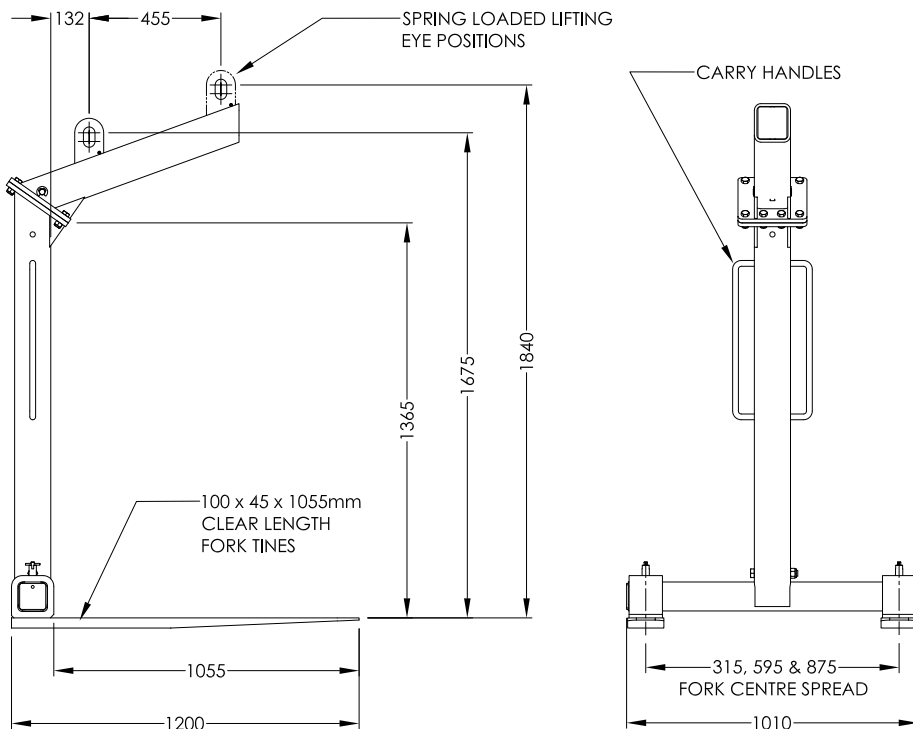

Crane & Overhead Lifting **Pallet Hooks**

Type PHD 2200 Pallet Hook

The PHD 2200 pallet hook is a versatile unit which features adjustable body height and fork tine width positioning, which makes this unit ideal for the transport and construction industry.

Load balancing is carried out by positioning the lifting ring to suit the centre of gravity of the load. Galvanised finish.

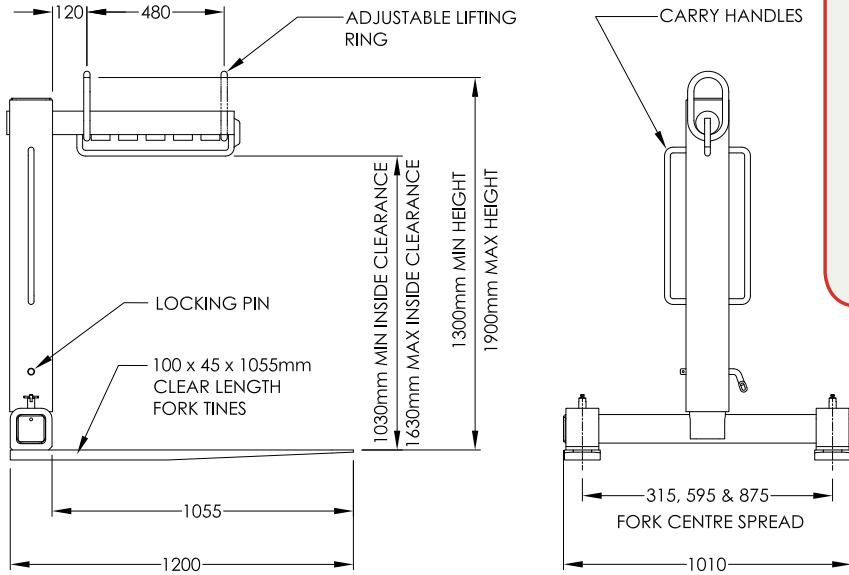

- Safe Working Load: 2200 kg
- Load Centre: 600 mm
- Unit Weight: 215 kg

Type PHN 4500 Pallet Hook

A heavy capacity pallet hook suitable for loads up to 4.5 tonne. Fully adjustable tines out to a maximum of 1200mm make this unit extremely versatile.

Load balancing is carried out by positioning the lifting ring to suit the centre of gravity of the load. Enamel paint finish.

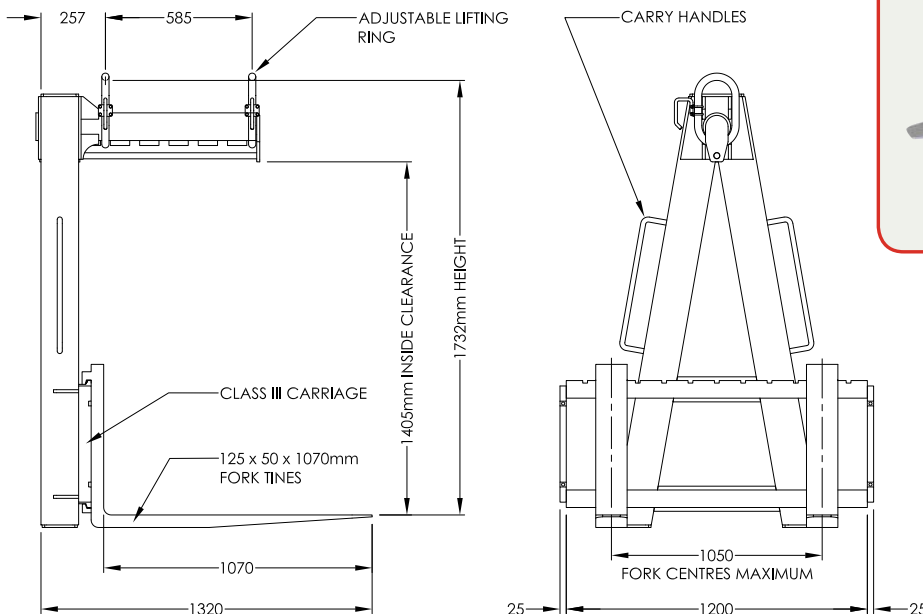

- Safe Working Load: 4500 kg
- Load Centre: 600 mm
- Unit Weight: 456 kg