

Forklift Attachments **Work Platforms**

Type WP-OP Order Picker Platform

Manufactured in strict accordance with AS 2359.1 and AS2359.6, the WP-OP Order Picking Cage must only be lifted by a dedicated 'Order Picking Forklift'. They can be custom made to suit individual forklifts and applications. The load capacity of the forklift will restrict the actual load capacity of the Order Picking Cage. Enamel paint finish.

- Safe Working Load: 1000 kg
- Load Centre: 600 mm
- Fork Pocket Size: 140 mm x 66 mm
- Fork Pocket Centres: 560 mm
- Unit Weight: 180 kg

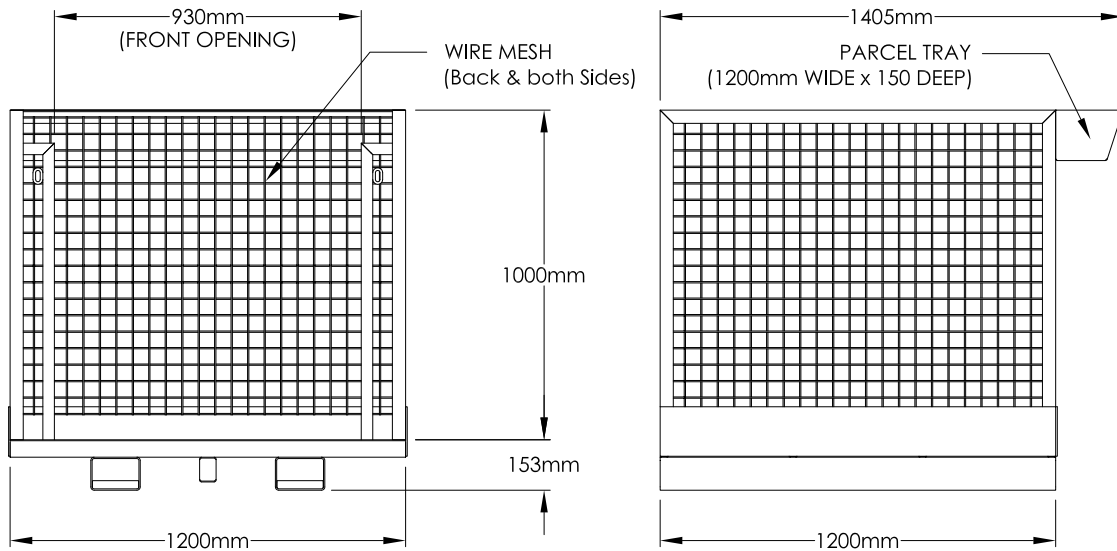

(Standard cage specifications shown)

Type WP-OPG Order Picker Platform

Built to the same dimensions as the standard WP-OP, but also fitted with a full width outward opening gate, enabling access to stock where required. Enamel paint finish.

